

# S75468 PAC-Minitrax-WMB2, S75467 PAC-Minitrax-CMB2 Light Duty Wall & Ceiling Mount Bracket

## ■ PRODUCT FEATURES

- Light duty wall & ceiling mount
- Adjustable swivel head
- Die cast and aluminum
- Cable feedthrough hole conceals the wiring
- Maximum load Approx 5.0 kg

The PAC-Minitrax-WMB2 and CMB2 are light duty wall and ceiling mount brackets designed for use with the PAC-Minitrax-22x and the EVO Vandalproof Domes.

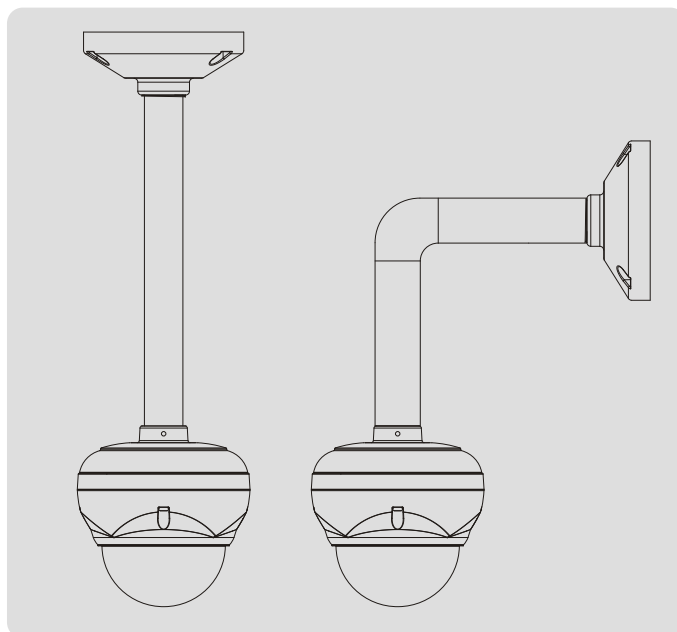

## ■ SPECIFICATION

Construction	Aluminum and steel
Pipe Specification	1" PT TAP
Maximum load	Approx 5.0 kg
Dimension	See dimensional outline
Weight	Unit 1.3 kg

## ■ SUITABLE FOR

S74969 - PAC-Minitrax-22X  
S39393 - PAC-Minitrax-10X  
S41671 - EVO-VPDIRVF540-4.0-9  
S41897 - EVO-VPDDNVF540-2.6-6  
S41898 - EVO-VPDDNVF540-4-9

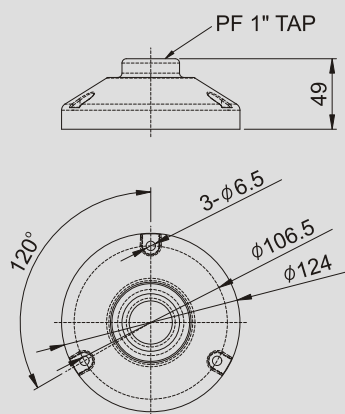

[ Mount Base Size ]

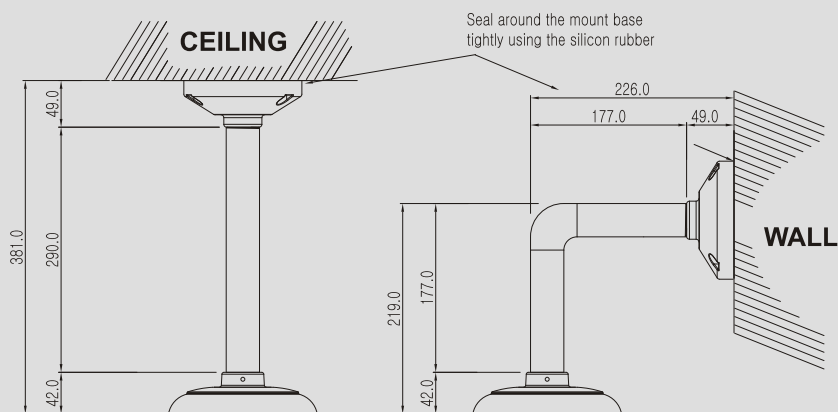

[ Dimension Drawing ]

Available from:

