



PA402 Mount

POLE MOUNT, SPECTRA® AND LEGACY® ADAPTER

Product Features

- Low Cost
- Rugged Construction
- Supports up to 75 Pounds (34 kg)
- Pole Mount Adapter for Spectra® and Legacy® Wall Mounts (IWM Series, IDM4018, and LWM41)
- Design Includes Mounting Studs for Quick, Simple Installation of Wall Mount



PA402 SHOWN WITH REMOVABLE BLOCK-OFF PLATE

The **PA402** is a pole mount adapter designed for use with Spectra® and Legacy® wall mounts. For Spectra, DF5, or DF8 Series pendant domes, use the IWM Series and IDM4018 wall mount. For Legacy positioning systems, use the LWM41 wall mount.

The LWM41, IWM Series, or IDM4018 wall mount is secured to the **PA402** by four 5/16-inch mounting studs; nuts and split lock washers are supplied.

Constructed from aluminum, the **PA402** is capable of supporting up to 75 pounds (34 kg) and features a cable feedthrough hole for easy routing of video and power cables. A block-off plate is included for non-feedthrough outdoor applications.

The **PA402** is for use on poles having a minimum 3-inch diameter. Mount is supplied with stainless steel mounting straps that are 28.5 inches (72.39 cm) long.

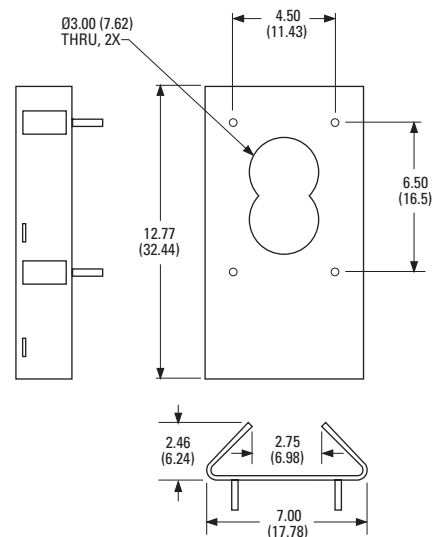

NOTE: VALUES IN PARENTHESES ARE CENTIMETERS; ALL OTHERS ARE INCHES.



DataFAX
SPEC: 2274
MANUAL: 22746

C274 / REVISED 10-03



TECHNICAL SPECIFICATIONS

MODEL

PA402 Pole mount adapter for IWM Series, IDM4018 and LWM41 wall mounts

RELATED PRODUCTS

IWM Series	Wall mount with cable feedthrough for use with Spectra, DF5, or DF8 Series pendant style domes.
IDM4018	Wall mount with removable front end cap and cable feedthrough for use with Spectra, DF5, or DF8 Series pendant style domes.
LWM41	Legacy wall mount. For use with Legacy integrated positioning systems.
EA4348	EWM adapter plate. Allows an EWM wall mount to be installed on a PA402 for use with an Esprit Series integrated positioning system.

MECHANICAL

Adapter Mounting	Four 5/16-inch mounting studs (nuts and split lock washers supplied) for attaching LWM41, IDM4018, EA4348, or IWM Series mount
Mounting Method	Slots for mounting straps; three stainless steel straps supplied. Strap length 28.5 inches (72.39 cm)

GENERAL

Construction	5052H32 aluminum, 0.190-inch (4.8mm) thick
Finish	Gray polyester powder coat
Maximum Load	75 lb (34 kg)
Unit Weight	3.48 lb (1.58 kg)
Shipping Weight	5 lb (2.27 kg)



Pelco Worldwide Headquarters:
3500 Pelco Way, Clovis, California 93612-5699 USA
USA & Canada Tel: (800) 289-9100 • FAX (800) 289-9150 • DataFAX (800) 289-9108
International Tel: (559) 292-1981 • FAX (559) 348-1120 • DataFAX (559) 292-0435
www.pelco.com

Legacy® and Spectra® are registered trademarks of Pelco.
Specifications subject to change without notice.
©Copyright 2003, Pelco. All rights reserved.